

Experimentally Validated Numerical Simulation of Heat Transfer Behavior of Dissimilar AA5052-AA6061 Plates in Friction Stir Welding

Vishwanath M M ^{a*}, Dr. N Lakshamanaswamy ^b

Dept of Mechanical Engineering UVCE, BUB , Bangalore, India.

Email: ^avishwanath.malnad@gmail.com, ^bnlsvce@yahoo.co.in

*Corresponding Author

DOI : 10.22486/iwj/2018/v51/i4/176797



ABSTRACT

Friction Stir Welding is a unique type of metal joining process in solid state, where the heat generation takes place due to the friction between the rotating tool and work piece. It is generally used to join all series of Aluminum alloys with good strength and also some metallic alloys that finds difficult in welding through regular fusion welding techniques. The metal joining takes place in the solid state as the metal to be welded reaches about 80% to 90% of its melting temperature. The joining of metals in friction stir welding does not require any filler metals all classes of Aluminium alloys can be joined and in some desirable cases dissimilar metal compositions and Aluminium metals composites can be joined satisfactorily. Joining of dissimilar metals has become a trend in the industries like aerospace, automotive chemical etc. as it eliminates the materials which are costlier where ever not required. In the present study an experimental investigations are made to study the heat transfer behavior by determining the temperature distribution in AA5052-AA6061 plates during the Friction Stir welding. A three dimensional transient analysis is made by using ANSYS finite element analysis software. Thermocouples are placed at the suitable locations and the same point the temperature readings were taken from the simulation results. The experimental data is compared with the numerically simulated results. The numerical simulations results obtained agree the experimental data obtained.

Keywords: Dissimilar metals; Aluminum alloy series; Friction Stir Welding; FSW; Heat Source model; Transient analysis.

1.0 INTRODUCTION

The art of FSW was first evolved in 1991, invented by The Welding Institute (TWI), Great Abington, Cambridge of United Kingdom and is considered as the solid state metal joining technique initially applied for joining of Aluminium plates. The friction Stir Welding unlike other fusion welding technique does not use any filler metals, cover gasses or flux and consumes very energy. The FSW is considered as the Green technology in welding as the process is environmental friendly without producing smoke. The friction stir welding is made by creating

the heat caused by friction therefore, it consists of a hardened tool designed with shoulder-pin arrangement made to rotate on the work piece surface to create friction and is traversed in the direction of weld to form a joint. The joining of metals does not require any filler metals and all the classes of the Aluminium alloy series starting from 1xxx to 7xxx alloys, as well as the newer Al-Li alloys can be joined with different compositions and in some desirable cases the dissimilar Aluminium alloys and the Aluminium metal composites can be joined satisfactorily. In addition the Friction Stir welding has metallurgical and dimensional benefits like solid state joining,

lesser distortion of work pieces, better geometrical stability, better metallurgical properties, absence of cracking, environmental benefits like absence of shielding gases that produces smoke, no grinding wastes and solvents requirements, consumable material savings and Energy benefits like require very less energy, less material usage, less fuel usage due to reduction in weight. The heat transfer studies in FSW is very significant in determining the quality of the weld. Research are made and many investigations are under progress in experimentally validated Numerical or FEM analysis of the thermal and Mechanical nature in the FSW of Aluminium alloy series with similar and dissimilar composition. McClure et al. [1] and Tang et al. [2] carried an experiment to measure the temperature distribution behavior in FSW to study heat transfer behavior in the welded joints and the joining materials.

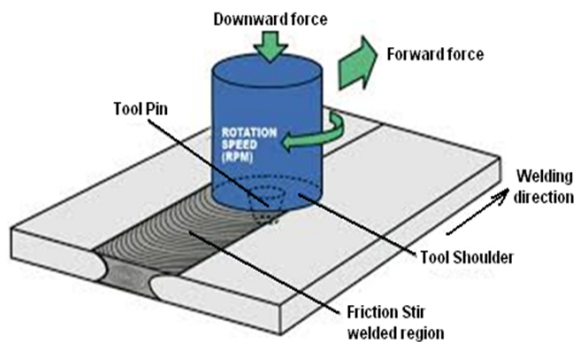

Fig 1 : Friction Stir Welding Process

The study was considered that heat is generated at surface of the tool called tool shoulder and then observed how the generated heat is conducted to the plate. Chao and Qi [5,6] made an experimental study to understand the temperature distribution and developed a moving heat source model by using FEA for validating the temperature curves with the experimental and evaluated the residual stress and distortion present in FSW. In this study the heat transfer in both tool and work piece were taken into account. Very recently Song and Kovacevic [7] investigated on a heat source model moving in a 3D co-ordinate system by adapting FEM technique to minimize the risk in modeling of the rotating tool in movement while welding in friction stir welding. Nandan et al.[8] developed a 3D model to study the plastic flow behavior in materials , the temperature distributed regions for experimental validations.

Qasim M Doos et al.[9] made a numerical study by developing two different transient thermal and fluid thermal models. the results concludes that the results of thermal model developed was better agreement as compared to the fluid thermal model. Rajamanickam et al. [10] made a investigation on the thermal behavior of aluminium alloys in FSW by developing thermo-mechanical numerical model using FEM technique and suggested that the thermal models are very useful in obtaining the temperature data in the vicinity of tool shoulder. Hani et al. [11] made an extensive investigations on FSW of copper alloys. In this study the different for the tool is used and the same is developed in the numerical model. The numerical simulation made and data obtained are more reasonable with the experimental work carried. Hamed Pashazadeh et.al. [12] made the numerical investigation for welding of copper by FSW. In this study a numerical models were developed to understand the thermal behavior around the weld joint and observed that heat distribution is not similar on either side around the joint and was observed that peak temperature is always occur behind the tool pin. Chen and Kovacevic [13] made a investigation to study the thermal and mechanical behavior of aluminum AA6061-T6 Alloy. In this investigation a 3D thermal model was developed and simulation is made by using commercial FEM code ANSYS.

The present investigation focus on the thermal behavior in FSW of dissimilar Aluminium alloys AA5052-AA6061 plate. The experimental work is carried out for the selected combination of dissimilar Aluminium alloys plates with suitable arrangement for the temperature data with data acquisition and transferred to the computer and numerical simulation is carried out by FEA software ANSYS. Pavelic circular disc heat source model, Thermo – Mechanical properties Aluminium alloys AA5052-AA6061, convective boundary conditions are applied during the numerical simulation process. Finally the results obtained by the numerical simulation is examined with the simulation results.

2.0 EXPERIMENTAL INVESTIGATIONS

The experimental investigations are carried to obtain the temperature data's for the joining of dissimilar AA5052-AA6061 plates by FSW. The following **Fig. 2** shows the FSW of the AA5052-AA6061 plates with a conventional milling machine with suitable arrangements required for the Friction stir welding.

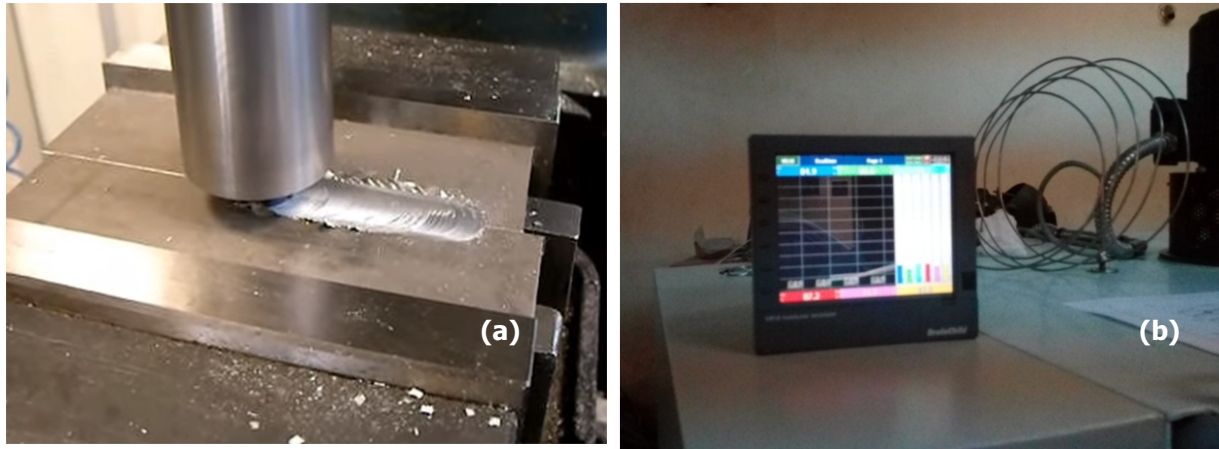

Fig 2 : a) Friction Stir Welding of AA5052-AA6061 plates with a conventional milling machine. b) Temperature – time measurement with data acquisition.

The experiment is conducted for the friction stir welding of dissimilar combination of AA5052-AA6061 plate samples having the dimension 300mm length, 150mm width and 6.35mm thickness. The friction stir welding is carried out for the rotational speed of tool between 1100rpm and the traversed speed of 360 mm/min. the tool is of two sided straight pin type FSW tool made up of Tungsten carbide – 10% Cobalt. The tool has the outer diameter of 25mm, length 60mm and the pin is of 10 mm outer diameter and 5mm height. Suitable clamping arrangements are made to hold the work piece. Both the end clamping and the bottom supports are made to hold the plates firmly. Due to the friction between tool and the plate there will be an intense plastic deformation of the metal in and around the rotating tool therefore placing the thermocouple is very important to obtain the temperature distribution.

Four K- type thermocouples 3 mm Mineral Insulated 2 meter long with quick detachable connector, Tip fixing bolt type, bolt 6mm x 15 mm are pinned from the bottom of the plate where the temperature can be measured up to 1000°C at the distance of 12mm and 16mm both on right and left sided AA5052-AA6061 plates from the weld centre the locations of the thermocouple is as shown in the **Fig. 4**. TC1, TC2, TC3 and TC4 represent the thermocouples locations. The temperature output data is obtained by the Temperature Recorder 'Brain Child' make PR series - 6 Channel of 4.5" TFT touch screen with data acquisition where the temperatures are recorded with respect to time and the experimentally recorded data are then transferred to the computer and necessary graphs are plotted.

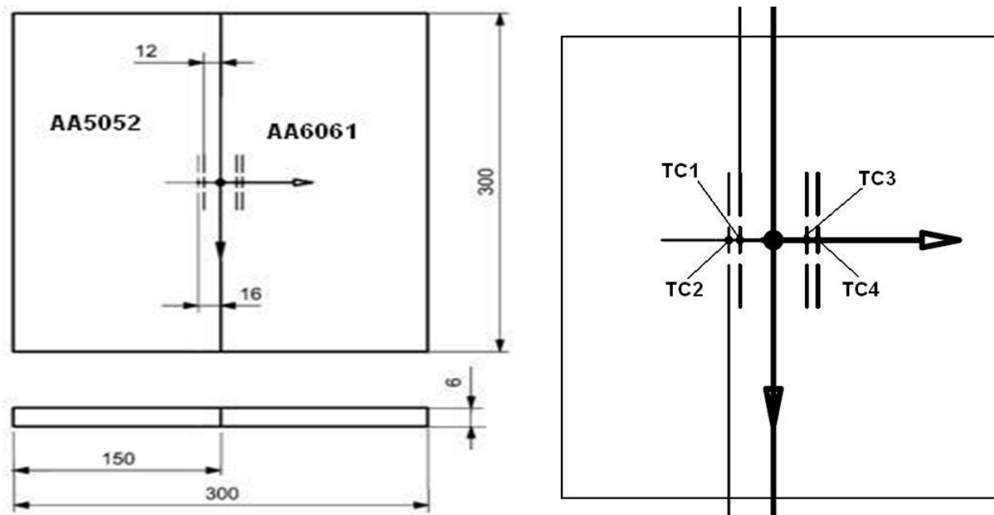

Fig 3 : Model dimension and thermocouple location.

3.0 NUMERICAL MODELING AND FEA SIMULATION USING ANSYS

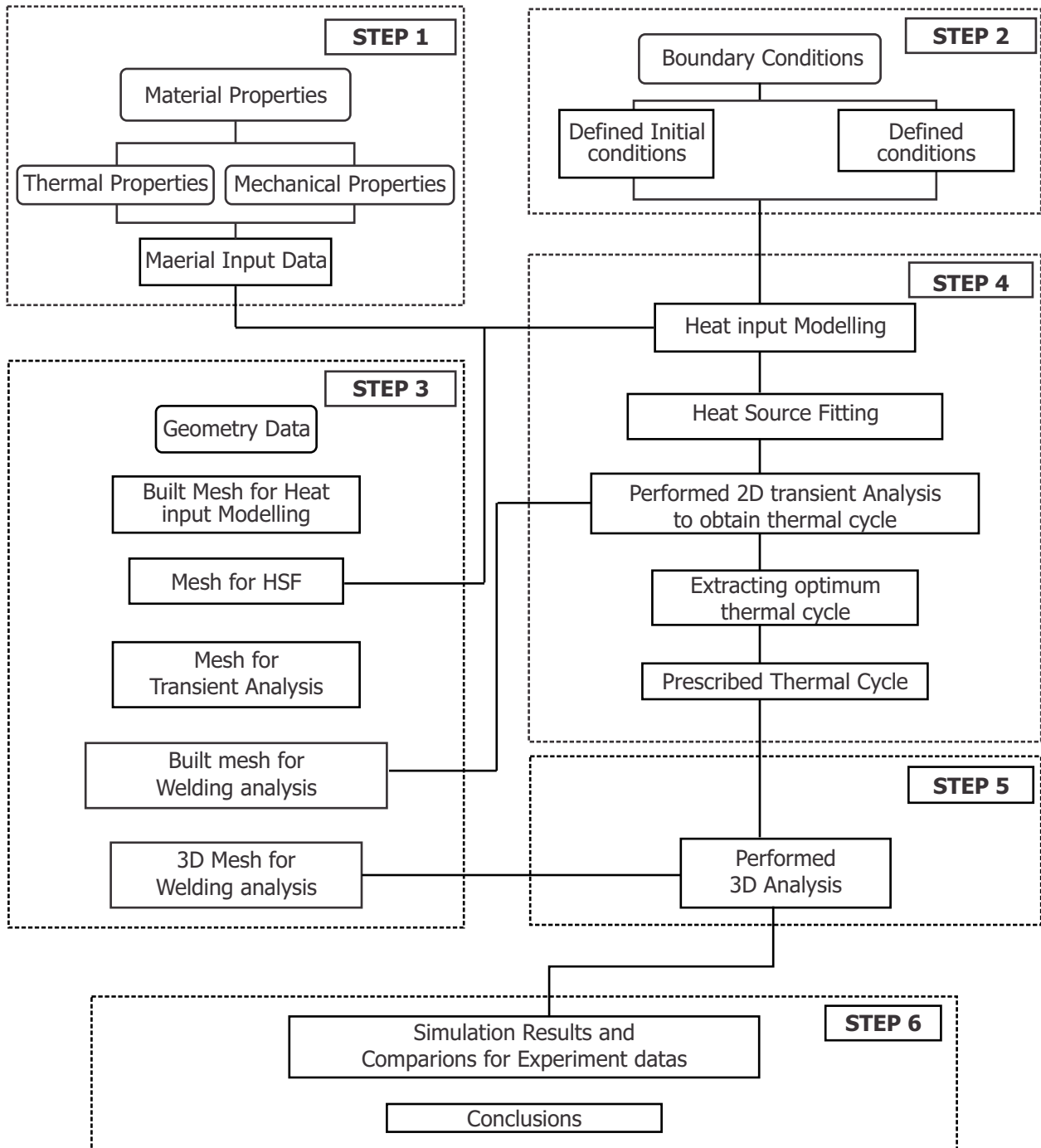

Fig 4 : Flow chart for the numerical simulation of FSW

A three dimensional numerical models are developed and mesing as been made, but in order to simulate the process, circular disc eat source model proposed by Pavelic is made to apply on the contact surface where the tool shoulder and metal plates to be joined in contact for friction with the moving heat source in the FEA software ANSYS. The distribution of temperature during FSW of dissimilar AA5052-AA6061 plates is analyzed. The temperature distribution curves observed during the numerical simulation is compared with temperature data obtained from the experimental investigation to validate the simulation process. The following flow chart shows the brief details of numerical simulation performed.

3.1 Temperature Dependent Material Properties

The transient heat transfer studies temperature distribution is important factor to know the thermal behavior in the weld plates. The heat balance equation consists of Temperature dependent material properties like enthalpy, thermal conductivity, density, specific heat, etc. These material properties generally dependent on the temperature and is important for the heat transfer studies in welding. ANSYS software package allows researchers to incorporate these properties for the type of the metals been modeled which in turn helps for further simulation. The thermal properties of the materials AA5052 and AA6061 plates used in the present numerical analysis are tabulated in **Table 1** and **Table 2**. As the FSW ia solid state welding process thermal properties in the molten region are neglected.

Table 1 : Thermal properties of AA5052

Temperature (°C)	Density (kg/m³)	Specific heat (kJ/kg°C)	Thermal conductivity (W/m°C)	Enthalpy (GJ/m³)
10	2781.25	0.9	162.5	0.025
80	2756.25	0.98	168.75	0.200
180	2695	1.07	193.75	0.467
280	2650.5	1.1	206.25	0.819
380	2610.66	1.15	225	1.118
480	2605	1.2	237.5	1.466

3.2 Geometrical modeling and Meshing

The 3D Modeling and Meshing required before simulation of welding process and is represented in the **Fig. 5** and **Fig. 6**. 3D

Table 2: Thermal properties of AA606

Temperature (°C)	Density (Kg/m³)	Specific heat (KJ/kg°C)	Thermal conductivity (W/m°C)	Enthalpy (GJ/m³)
25	2700	0.896	167.2	0.060
93.3	2685	0.978	170.8	0.229
148.9	2667	1.004	184.4	0.385
204.4	2657	1.028	192.5	0.540
315.6	2630	1.078	207.3	0.872
371.1	2620	1.104	217.1	1.041
426.7	2602	1.133	223.6	1.222

modeling is made for both the work piece and tool which is positioned such that the tool can move during the simulation as identical to the experimental welding. The meshing is made in the meshing available in the ANSYS workbench with 212859 nodes and 129051 elements which help in location the position of the thermocouple at the node and to study the temperature distributions on that location. The dimensions are maintained for the tool and work piece used experimentally.

3.3 Heat Source Modeling

Circular disc' model in 1965 was proposed by Pavelic et a1.[3] is more realistic as compared to the point heat source and line heat source developed by Rosenthal, as it distributes the heat input over a source area. These models were most commonly applicable in the solid state welding processes like friction stir welding, where the temperature is 15 -20% less than the melting temperature of the welded joints. This model give accurate results in the arc welding with the better heat distribution in the molten Heat affected zones. The **Fig. 6** shows the heat distribution on a circular disc model presented by the Pavelic. This circular disc model is more realistic and practical as compared to point and line heat source models because the heat distribution takes place over a source surface area. This disc model also allows the convective and radiation boundary conditions for the better heat distribution.

The two dimensional heat flux at the surface of work piece at a tool shoulder of radius 'r' is represented as,

$$q_r = q_e - Cr_2W/m^2 \quad \dots (1)$$

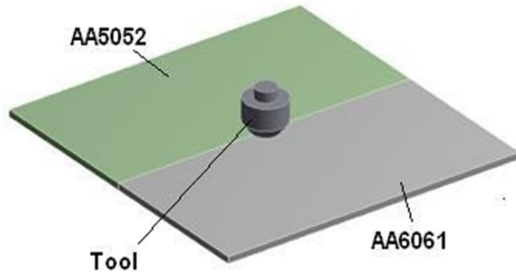

Fig 5: 3D modeling of the tool and work piece.

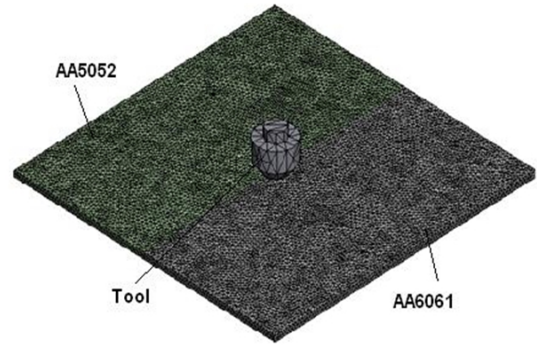

Fig 6 : Finite Element meshing of the tool and work piece

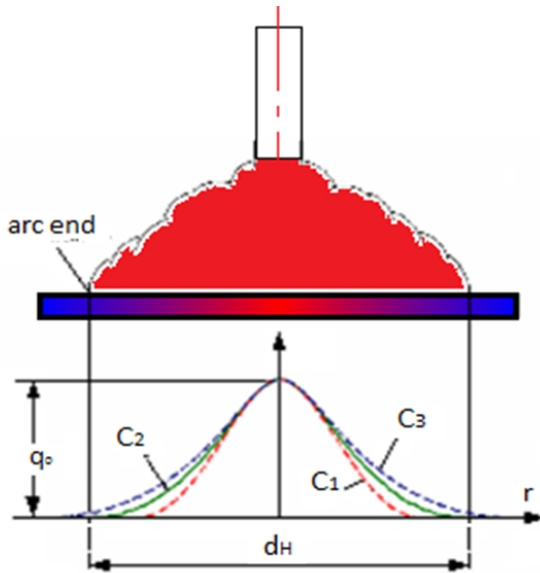

Fig 7 : 2-D Pavelic's model

Where:

q_r is the heat flux at the contact surface at radius ' r ' in W/m^2 , q_0 is the maximum heat flux obtained at the welded joint in (W/m^2), C is the distribution coefficient in m^{-2} .

3.4 FEA simulation using ANSYS.

FEA simulation is made in this investigation by ANSYS Workbench 15.0 software. In Friction Stir welding process numerical simulation is carried by circular disc moving heat source model. The simulation carried is only to analyze the thermal behavior during the Friction stir welding of AA5052-AA6061 series plates. For performing the simulation, transient heat transfer analysis was made to obtain the temperature distribution curves and validated with experimental data.

H: 1
Temperature
Type: Temperature
Unit: °C
Time: 25.25

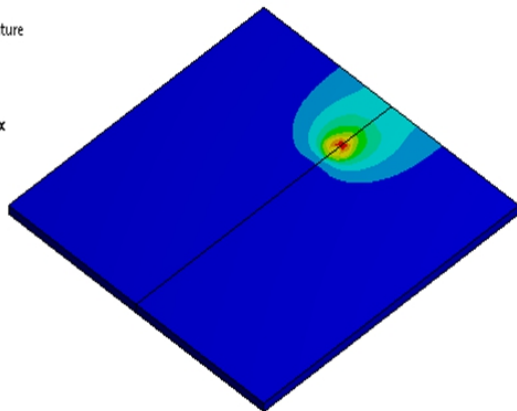
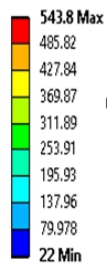

H: 1
Temperature
Type: Temperature
Unit: °C
Time: 49.7

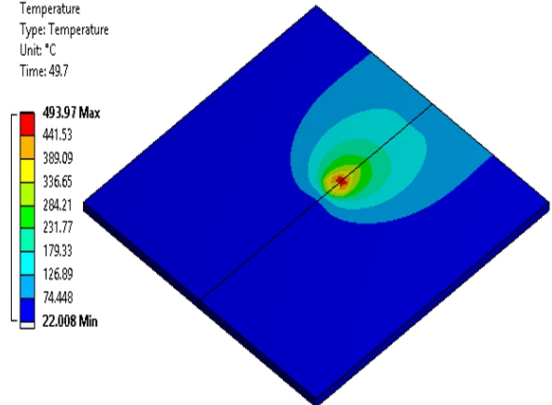
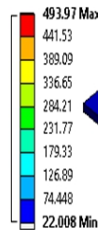

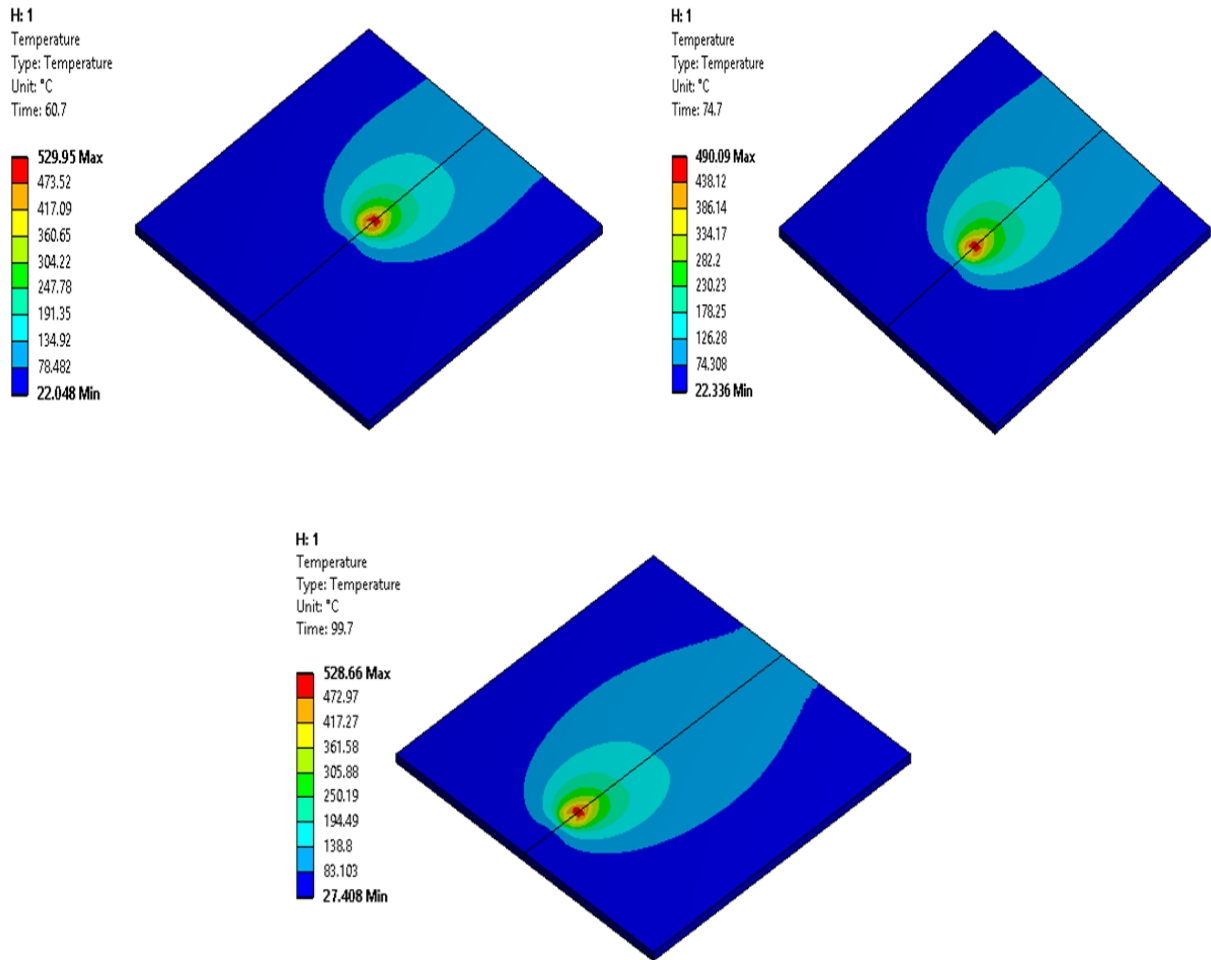

Fig 8 : Numerically simulated temperature contours of AA5052-AA6061 plates at time steps (a) 30s (b) 60s (c) 90s (d) 120s and (e) 150s during FSW welding.

The above figure represents numerically simulated temperature contours for Aluminium alloy AA5052-AA6061 plates in time steps (a) 30s (b) 60s (c) 90s (d) 120s and (e) 150s during FSW welding using ANSYS workbench 18. The peak temperature attained during the process is 543.8°C at the beginning 30 seconds and the maximum temperature of 493.57°C, 529.95°C, 490.09°C, 528.66°C were observed during next 60, 90, 120 and 150 seconds respectively. The above peak temperature indicates the plastic formation of the metal before the melting point require for friction stir welding. The peak temperature attained almost at the middle near the tool pin and distributed gradually as the circular disc moving from one end to the other end. The minimum temperature of 74°C to 79°C is present till the welding ends.

4.0 RESULTS AND DISCUSSIONS

The Temperature -Time curves during the transient heat transfer in the AA5052 and AA6061 plates of Friction stir welding were extracted by the temperature output data is obtained by the Temperature Recorder 'Brain Child' make PR series - 6 Chanel of 4.5" TFT touch screen with data acquisition by placing the K-Type thermocouples at 12mm and 16mm from the welding line to validate the numerical simulated results in ANSYS workbench. A peak temperature was recorded in temperature recorder as the welding tool reaches the thermocouple and as the tool departs from the centre the heat dissipation takes place by conduction and convection. **Fig. 9** and **Fig.10** shows the Temperature -Time curves experimental and numerical simulation data obtained from the investigation.

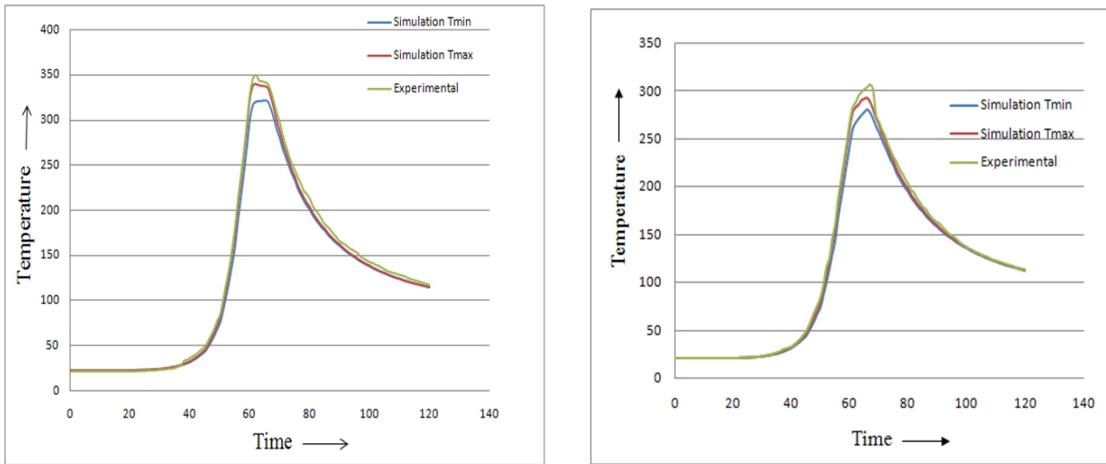

Fig 9 : Comparison between Experimental and Numerically simulated Temperature – Time curves for AA5052 plate at a distance of 12mm (left) and 16mm (right) from weld centre line.

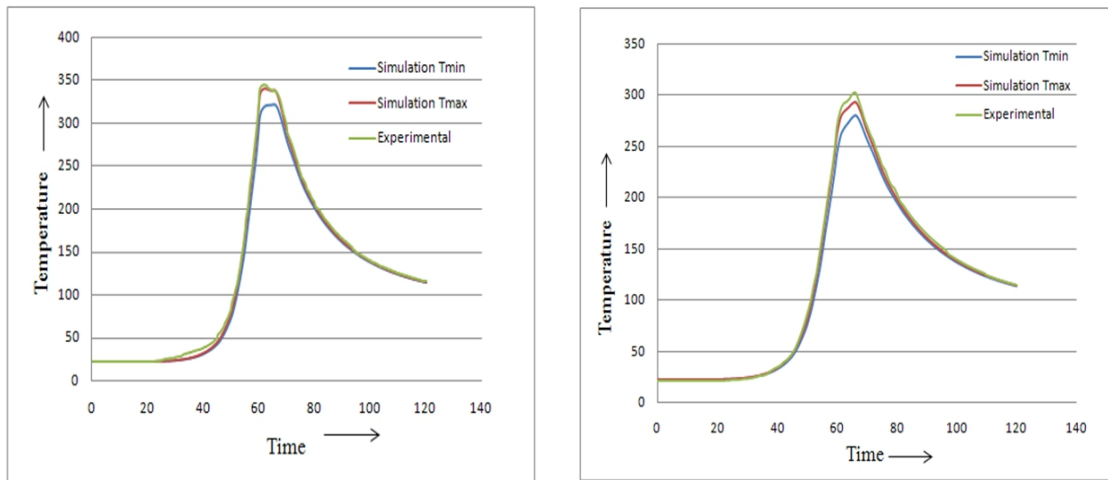

Fig 10 : Comparison between Experimental and Numerically simulated Temperature – Time curves for AA6061 plate at a distance of 12mm (left) and 16mm (right) from weld centre line.

Temperature distribution curves plotted shows a similar nature of curves exists in experimental temperature data and numerical simulation temperature data. There is a very small deviation in the numerical simulation results because of thermal inertia of measuring device and heat transfer coefficient of the air with respect to temperature is not considered only a standard value of 30W/m^2 of heat transfer coefficient is considered in the study as per the survey. from the **Fig. 9** and **Fig. 10**. The peak temperature in the numerical simulation of AA5052 plate is 341°C at 62 second at the centre of the plate for the thermocouple placed at 12mm

distance from the weld centre and 293°C at 66 second for the thermocouple placed at 16mm distance. There is about 4 second difference in obtaining the peak temperature due to the conduction lag occurred by thermocouple mounting. The peak temperature in the numerical simulation of AA6061 plate is 339°C at 62 second at the centre of the plate for the thermocouple placed at 12mm distance from the weld centre and 291°C at 66 second for the thermocouple placed at 16mm distance. There is about 4 second difference in obtaining the peak temperature due to the conduction lag occurred by thermocouple mounting. Similar nature of curve is obtained in experimental observations.

5.0 CONCLUSIONS

The experiment is conducted for dissimilar combination of AA5052-AA6061 plate samples having the dimension 300mm length, 150mm width and 6.35mm thickness from Friction Stir Welding technique, temperature data obtained and numerical simulation were carried with surface circular disc Pavelic heat source model using ANSYS Workbench 15.0 software. The experimental data is compared with the numerically simulated results and draws the following conclusions:

1. The heat distribution are similar in both AA5052 and AA6061 Aluminium alloys as indicated by the indicated in the temperature contours due to the nearest thermal properties of both metals.
2. The nature temperature curve obtained in the experimental is identical with the numerical simulation curve indicating the right choice of using Pavelic's Circular disc model with moving heat source.
3. The temperature curve indicate the occurrence of Friction stir welding in the plastic state and the maximum value temperature attained in the simulation is well agreement with the Experimental data indicating the validated simulation study of heat transfer behavior of the friction stir welding process.

REFERENCES

- [1] McClure J C, Tang T, Murr L E, Guo X, Feng Z (1998); A Thermal Model of Friction Stir Welding, Proceedings of the 5th International Conference Trends in Welding Research, J. M. Vitek et al. eds, Pine Mountain, USA, pp. 590-595.
- [2] Tang W, Guo X, McClure J C, Murr L E, Nunes A (1988); Heat Input and Temperature Distribution in Friction Stir Welding, Journal of Materials Processing and Manufacturing Science, 37(2), pp. 163-172.
- [3] Gould J, Feng Z (1998); Heat Flow Model for Friction Stir Welding of Aluminum Alloys, Journal of Materials Processing and Manufacturing Science, 37(2), pp. 185-194.
- [4] Colegrove P, Painter M, Graham D, Miller T (2000); 3 Dimensional Flow and Thermal Modeling of the Friction Stir Welding Process, Proceedings of the Second International Symposium on Friction Stir Welding, June 26-28, Gothenburg, Sweden.
- [5] Chao Y J, and Qi X (1999); Heat Transfer and Thermo-Mechanical Analysis of Friction Stir Joining of AA6061-T6 Plates, Proceedings of the First International Symposium on Friction Stir Welding, June 14-16, Rockwell Science Center, Thousand Oaks, California.
- [6] Yuh J Chao, X Qi, W. Tang (2003); Heat Transfer in Friction Stir Welding -Experimental and Numerical Studies, Journal of manufacturing science and engineering, 125, pp. 138-145.
- [7] M Song, R Kovacevic (2003); Thermal modeling of friction stir welding in a moving co-ordinate system and its validation, International Journal of machine tools and manufacture, 43, pp. 605-615.
- [8] R Nandan, G G Roy, T Debroy (2006); Numerical simulation of 3D heat transfer and plastic flow during friction stir welding, Metallurgical and materials transactions, 37(a), pp. 1247-1259.
- [9] Qasim M Doos, J J Muhsin, D R Sarmad (2008); Analysis of friction stir welds. Part I: Transient thermal simulation using moving heat source, First regional conference of Eng. Sci. NUCEJ, 11(3), pp. 429- 437.
- [10] Rajamanickam N, V Balusamy, P R Thyla, G Hari Vignesh (2009); Numerical simulation of thermal history and residual stresses in friction stir welding of Al 2014-T6, Journal of scientific and industrial research, 68, pp.192-198.
- [11] Hani Aziz Ameen, Ahmed Hadi Abood, Nabeel Shallal Thamer (2013); Theoretical and experimental investigation of friction stir welding for copper alloy, AL-Qadisiya Journal for Engineering Sciences, 6(3), pp.332-351.
- [12] Hamed Pashazadeh, Jamal Teimournezhad, Abolfazl Masoumi (2014); Numerical investigation on the mechanical, thermal, metallurgical and material flow characteristics in friction stir welding of copper sheets with experimental verification, Materials & Design, 55, pp.619-632
- [13] Chen CM, Kovacevic R (2003); Finite element modeling of friction stir welding -Thermal and thermo-mechanical analysis, Journal of Machine Tools & Manufacture, 43, pp.1319-1326.