

# Energy-aware routing based on link utilization in domain network

*Aimed at the characteristic of the Software Defined Network (SDN), several green routing algorithms are proposed. However, there are many drawbacks consisted in the existing algorithms. Therefore, we propose a self-adaptive energy saving routing algorithm (LAR) which is based on residual bandwidth of links and SDN. The proposed algorithm makes the link utilization which is changing in real time as the link cost. It would obtain the topology information and link status to optimize and prune the topology for reducing the computing time of routing algorithm before selecting routing path. After a period of time, the incoming flows will automatically be gathered in heavily-loaded links. The links without traffic will be switched off while the whole network connectivity and QoS are guaranteed. Simulation results show that it is possible to reduce considerable energy consumption during off-peak hours and link energy saving can be up to 55%. And, the algorithm has the distinct advantage in terms of complexity and network performance comparing with related schemes.*

**Keywords:** Energy-aware routing, SDN, self-adaptive, link utilization

## 1.0 Introduction

The application of Internet technology not only brings convenience to production and human life, but also increases the burden on the natural environment and energy resources. Recently, the emergence of global haze weather makes human's living environment face up a great challenge; especially in China, air pollution has reached a serious harmful degree. It is a sharp warning for people and government who think environmental problems are something new. Thus, energy conservation has become the matter of concern to world. A IT green energy survey from IDC reports that we can save about 5.4 million kWh of electricity when 1000 traditional servers are reduced every year, which is equivalent to decreasing the consumption of 1944 tonnes of coal and the emission of 35093 tonnes carbon dioxide.

Messrs. Jingfan Tang, WeiFei, Min Zhang, Ming Jiang and Qicheng Wang, Institute of Software and Intelligent Technology, Hangzhou Dianzi University, Hangzhou 310018, China

For current Internet, the architecture is not optimized for energy saving and the energy efficiency of network is inefficient. To ensure network reliability, traditional network provides a redundant design on device level and link level, which will result in a waste of resources in the off-peak hours when many network components are idle cold state. Most of the network equipment work for 24 hours according to the peak load design while the network load is far lower than the peak load in most of the time [1]. The development of Software Defined Network (SDN) provides a new solution for the research of new network applications and future Internet technology [2].

The traditional methods of energy saving are divided into two types: system level and network level. Adaptive Link Rate (ALR) was proposed as means of automatically fast switching the data rate of a full-duplex Ethernet link to match link utilization which is on system level [3] [4]. Network dormancy mechanism is based on putting network components to sleep during idle times to reduce energy consumed in the absence of packet [5]. But these solutions require are design or replacement of existing network elements, which is difficult to implement. So, some researchers also committed to some network level solutions, such as GNRE (Green algorithm based on network resource deletion). These solutions can reduce active network elements effectively, but they are not suitable for large-scale network and their running time is too long. Then, Young-Min kim et al. proposed a new ant colony-based self-adaptive energy saving routing scheme (A-ESR) in [6]. However, the complexity of the A-ESR algorithm is so high that the network performance will decrease.

In this paper, it presents a self-adaptive energy saving routing algorithm (LAR), which is an energy-saving intra-area routing algorithm combined with the characteristics of SDN and the concept of traffic aggregation. Under full connectivity and considering Quality of Service (QoS), we proposed a simple heuristic algorithm based on link utilization and depth-first search for route-forwarding. The contributions of the LAR scheme is given: (1) in constraint to the load balance, flows are automatically gathered into the heavily-load links until the switch-off links appear; (2) a new concept called

“best hop” will be introduced to aggregate the network traffic on the heavy loaded links. The routing policy will choose nodes have the largest value of “best hop” to construct the routing path; (3) the QoS constraints are taken into account when optimizing routing. Simulation results show that our algorithm have the considerable energy efficiency and better performance than other energy-saving algorithms. The paper is organized as follows. Section 2 states the related work of energy saving routing and energy-saving technologies in the context of SDN. Section 3 gives the problem formulation aimed at intuitive analysis and proposes a practical solution with heuristic algorithm. The experiments and the comparison with other algorithms are introduced in section 4. Section 5 concludes.

## 2.0 Related work

Many researches on energy-aware routing are optimized at component level or link level. However, this kind of optimization is achieved at the expense of network performance. In [7], it used SPTs and MPTs to close unnecessary links and performance study shows that more than 60% of links can be switched off while it did not consider the network availability and QoS requirements. The authors in [8][9] considered switching off nodes and links with some heuristic algorithms under a QoS threshold. A specific instance was presented in backbone networks while guaranteeing QoS [10], which can save a lot of power. However, the packets will be discarded when the destination of an incoming flow is a router that has been closed. Rui Wang et al. proposed greedy algorithms to minimize the power when putting idle ones to sleep under constraints of link utilization and packet delay in SDN [11]. Guan Xu proposed a bandwidth-aware energy efficient routing algorithm which can schedule flows to the queues of each link with SDN in data center networks [12]. In terms of WSNs, Yanwen Wang proposed a sleep scheduling algorithm (SDN-ECCKN) to take advantage of SDN [13].

The incoming flows were autonomously aggregated on specific heavily-loaded links and the unused links would gradually emerge in [6]. The A-ESR algorithm exploited the high self-adaptive ability of ant colony optimization method. By further analysis, the complexity of A-ESR algorithm was high and could not learn the network status by routing protocol in SDN network. In this paper, we introduce the concept of “best hop” by drawing on the concept of “traffic centrality” in A-ESR scheme to reduce the running time and improve the quality of service. In [14], it analyzed the design of green routing algorithms and evaluated the achievable energy saving, which indicated ISP (Internet Service Provider) would have to carefully choose the trade-off between the achievable energy efficiency gain and the robustness of the solution. To ensure robustness, Heng Lin proposed a robust energy-aware routing (REAR) scheme

based on a classical demand-oblivious routing algorithm, but it can only save 35% line card power [15].

Researchers studied on the routing algorithms based on ratio of bandwidth for congestion avoidance and load balance. On the known premise of traffic matrix, Yang Xiaoqin found out all the paths which satisfied conditions between the source node and destination node with DFS algorithm, and then selected path with the least utilization [16]. It is well known that finding out all paths between two points belongs to exhaustion method, and the shortcomings will be exposed once it is applied to a large-scale network. In [17], the available bandwidth of next-hop and link utilization was both considered, and link transmission capacity factor was introduced to make routing decision. While in [18], it replaced finding the least cost path with finding the path with minimization of maximum bandwidth utilization.

## 3.0 Problem definitions and algorithm

### 3.1. PROBLEM DEFINITIONS

The authors of [9][10] used integer linear programming to formulate the energy consumption minimized network (EMN) problem. We only focus on the energy consumption of links because of considering the network connectivity caused by switching off nodes. Formally, we model the physical network topology as an undirected graph  $G(V, E)$ , where  $V$  is the set of nodes (i.e. routers), and  $E$  is the set of links. A link that connects node  $i$  to its neighbor node  $j$  is denoted by  $l_{ij}$ . The set of neighbors of node  $i$  is denoted by  $\{N_i | i \in V, l_{ij} \in E\}$ . The energy consumption of each link is characterized by  $c_{ij}$ . The path  $P$  from source  $S$  to destination  $T$  is composed of a group of links  $(l_1, l_2, \dots, l_n)$  which are not duplicated. The EMN problem to solve is as follows: (1)

subject to:

$$\sum_{j \in N_i} f_{ij}^{ST} - \sum_{j \in N_i} f_{ji}^{ST} = \begin{cases} f^{ST}, \forall S, T, i = S \\ -f^{ST}, \forall S, T, i = T \\ 0, \forall S, T, i \neq S, T \end{cases} \quad \dots (2)$$

$$f_{ij} \leq c_{ij} \quad \forall i, j, l_{ij} \in E \quad \dots (3)$$

where equation (2) is the classical flow conservation constraint. Equation (3) states the condition of link load to be less than the link capacity.

### 3.2. REDEFINE THE EMN PROBLEM

According to previously described, traditional solutions of EMN problem still have several defects. Since SDN has a global vision of network, we do not need to search the information of network status additionally. Then, to solve the problems of the high complexity and very long running time of general energy-saving algorithms, we redefine this problem into a newer format. For  $\forall l_i \in E (1 \leq i \leq n)$  correspond to a cost value (Hop) denoted by  $d_{l_i}$ , the length of path denotes the total costs of path, i.e.,

$$\text{len}(P) = \sum_{i=1}^n d_i \quad \dots (4)$$

Then,  $C_{ij}$  and  $R_{ij}$  indicate the physical bandwidth and available bandwidth. Let  $f_{ij}^{ST} \in [0, t^{ST}]$  denote the amount of flow from S to T, where  $t^{ST}$  represents the traffic demand. The amount of traffic flowing on the link from  $i$  to  $j$  is denoted by  $f_{ij}$ . The concept of ‘‘best hop’’ will be defined:

$$H(k) = \alpha \eta_{ik} + (1 - \alpha) R_{ik}^{Nor} \quad k \in N_i, \alpha \in [0, 1] \quad \dots (5)$$

$H(k)$  evaluates the best hop of node, where can control the impact of link utilization and available bandwidth on the selection of next hop to avoid the excessive reuse of high bandwidth utilization of links. Let  $\eta_{ik}$  denotes the bandwidth utilization of link connected with.  $R_{ik}^{Nor}$  presents the normalization of available bandwidth because and are not the same order of magnitude, let  $R_{ik}^{Nor} \in [0, 1]$ . We can use the following formula to compute the link utilization:

$$\eta_{ij} = \frac{C_{ij} - R_{ij}}{C_{ij}} \quad \dots (6)$$

Given the previous definitions, it is possible to formalize this minimize active links problem as follow:

$$\text{Maximize} \left( \sum_{i=1} H(k) \right) \quad l_i \in P \quad \dots (7)$$

Subjected to:

$$\sum_{j \in N_i} f_{ij}^{ST} - \sum_{j \in N_i} f_{ji}^{ST} = \begin{cases} f^{ST}, \forall S, T, i = S \\ -f^{ST}, \forall S, T, i = T \\ 0, \forall S, T, i \neq S, T \end{cases} \quad \dots (8)$$

$$\text{len}(P) \leq D \quad \dots (9)$$

$$\eta_{ij} \leq \beta \quad \forall i, j, l_{ij} \in E \quad \dots (10)$$

The objective equation (7) maximizes the sum  $H(k)$  of each hop of optimal path. While equation (9) requires the length of path to be smaller than one value such as hop count, delay to ensure the reliability of network. Equation (10) ensures that the utilization of all links should below a given threshold.

### 3.3. ALGORITHM

Indeed, designers scale network into multiple connected autonomous systems for ease of management generally, and a single autonomous system will be divided into smaller areas. While in a large SDN network, it is not wise to only use a SDN controller to manage and control the entire network. Therefore, the SDN network will be zoned as several non-overlap SDN domains. The number of links which can be switched off should be maximized for energy conservation in every SDN domain. Fig.1 shows an overall architecture of the proposed green routing scheme. Obviously, this problem can be transformed into the longest-path problem according to the definitions. The longest path problem is well-known NP-Hard. Accordingly, the LAR algorithm adopts a heuristic

search method to select the best path with the local optimal search strategy to obtain an approximate solution of this problem. The green routing scheme is described in three phases:

Phase 1: In SDN network, network components will convey the network topology and traffic information to the SDN controllers. We can calculate the bandwidth utilization rate of all links in SDN domain by equation (3). After the analysis of global topological information, the links without traffic will be pruned. Next, we can sort the nodes with the standard of total flows through nodes to obtain the suitable alternate paths.

Phase 2: In this phase, the LAR algorithm will be performed. If optimal path length is bigger than the threshold value D or does not meet the QoS requirements, the algorithm will enable the candidate path. Subsequently, the flow will be forwarded to the next hop with the highest probability and traffic begin to aggregate on the heavy load links. Algorithm1 reports a schematic description of the heuristic. It takes stack as the storage structure function which calculates the best next hop according to equation (2) and equation (6). N denotes the maximum length of the routing path. We can switch off the unused links and sustain the whole network connectivity constraints.

Phase 3: The algorithm re-runs the Dijkstra algorithm and computes the shortest paths under the modified network.

---

#### Algorithm 1: Pseudo code description of the proposed heuristic

---

- 1: Sort links according to the size of load;
  - 2: The set of candidate paths between the nodes is generated according to the sorting result;
  - 3: **if** the length of path the threshold value D **then**
  - 4: **foreach** node that does not join the path array **do**
  - 5: **if** the node with the maximum is not visited in the set of neighbor
  - 6: **if** the bandwidth utilization of the link between and **then**
  - 7: select the node in with a second largest of,
  - 8: add it to the path array;
  - 9: **end if**
  - 10: **else** return the previous node in the path array
  - 11: **if** is the destination node  $n_{\text{dest}}$  **then**
  - 12: **return**  $p$
  - 13: **end if**
  - 14: **end if**
  - 15: **end for**
  - 16: **else** select the path in  $HP$
  - 17: **end if**
-

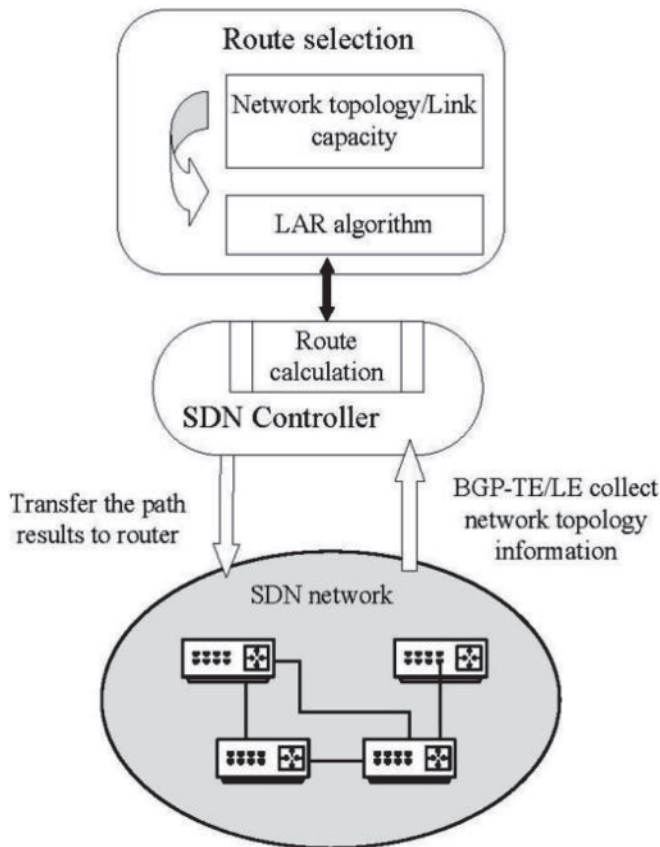

Fig.1 Green routing system architecture of SDN

#### 4.0 Performance evaluation

##### 4.1. COMPLEXITY

In this section, we analyze the complexity of each phase of the LAR solution and compare with other algorithms proposed in [8][10]. We denote network node and link with letters  $V$  and  $E$  respectively. Due to the higher performance of Fibonacci heap, we assume that Dijkstra algorithms time complexity is  $O(V\text{Log}V+E)$ .

To solve the problem of minimize the total power consumption, the authors of Kand B (2005) present a set of heuristic solutions explicitly. They considered starting these schemes by gathering the basic information include traffic matrix and topology through existing routing protocols (OSPF, EIGRP). In this phase, the complexity is bigger than Dijkstra algorithm and we cannot compute it exactly. Then, the heuristic methods which are divided into four steps will be performed in phase 2. Firstly, they sort the network components with some criterion. Then, the algorithm will check the network connectivity and links flow iteratively when it turns off an open resource. If these constraints are still fulfilled, the selected element will be powered off. The complexity of this phase is  $O(E\text{Log}E+EV^2\text{Log}V+E^2V)$ . Under the modified network topology, it will rerun OSPF routing algorithm and forward flow along the shortest paths.

Unlike the algorithm proposed in the preceding paragraph, it shows a new ant colony-based self-adaptive energy saving routing scheme (A-ESR) in [6]. It maintains the learned network status by employing a number of artificial ants instead of performing other routing protocol. In this phase, it needs a large number of artificial ants and frequent update of routing packet to ensure the accuracy of the information, and perform many arithmetic operations to process routing packet. We assume that  $M$  is the number of ants and let  $T$  denote the iteration number, the time complexity can be expressed as  $(V(V-1)M*T/2)$ , so the complexity is at least  $O(V^4)$ . During the second phase, A-ESR takes no action. Finally, A-ESR algorithm will forward the incoming flows with pheromone trails and the concept of traffic centrality will be calculated by an extra formula. Accordingly, the complexity of the third phase is bigger than the previous algorithm.

According to the energy efficient routing programme with three phases presented in this paper, we analyze the time complexity of each phase. In phase 1, since gathering of network information and status will be done by SDN controller, we do not need to consider the complexity. Then, we should perform the pruning operation and sort algorithm for links, so the complexity is about  $O(E\text{Log}E)$ . In phase 2, the complexity of the LAR algorithm which based on DFS algorithm is  $O(V^2)$  in the worst cases. When the unused links appear, the network will be optimized by re-running the Dijkstra algorithm for the normal operation of network. Table 1 briefly explains the time complexity of each phase of three algorithms. It shows that the complexity of our algorithm is lowest.

TABLE 1: TIME COMPLEXITY OF ROUTING PHASES

Heuristic algorithm	A-ESR algorithm	LAR algorithm
$O\left(\begin{matrix} E\text{Log}E + EV^2\text{Log}V \\ + E^2V + V\text{Log}V + E \end{matrix}\right)$	$> O(V\text{Log}V + E + V^4)$	$O(V\text{Log}V + E\text{Log}E + V^2 + E)$

##### 4.2. PERFORMANCE

In this section, we evaluate the LAR algorithm by implementing simulation programme with C++ and using the NS-2 simulator. To get closer to the real intra-domain network environment, we have considered a real network topology from intra-regional traffic distribution of Asia which includes 19 nodes and 42 links. As shown in Fig.2, there are four different capacity of links: 1G, 800M, 500M and 100M, respectively. Under this topology and specific traffic flows according to a night pattern, we run the LAR algorithm to aggregate traffic into a part of links, and then links which can be switched off will appear. Fig.2(b) reports the individual links switched off, which are expressed as dotted-line in the case of guaranteeing full network connectivity and links are never loaded more than 50%.

Observing the result of the closure of links in Fig.2, we can see that it is possible to achieve a higher rate of links



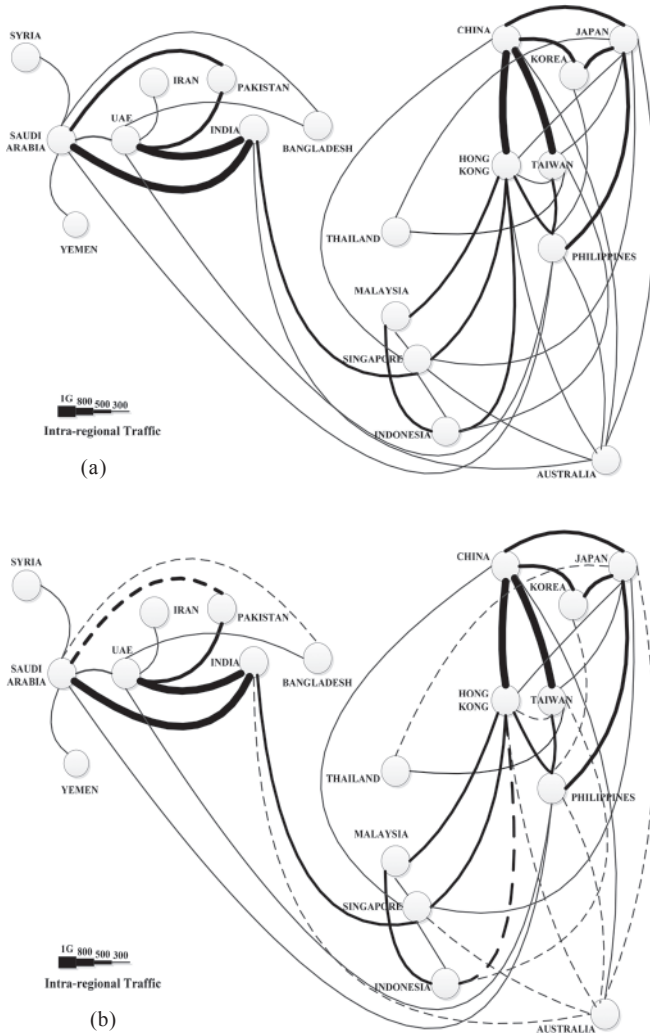

Fig.2(a) Custom network topology (b) Modified topology after LAR algorithm performed

turned off for the node with higher degree. Therefore, we generate several topologies considering  $V_d$  as the average degree of nodes for different network size, it can be calculated by the equation (11). Fig.3 reports the percentage of links switched off for  $V_d \in (2.0, 5.0)$ . It is interesting to see that the

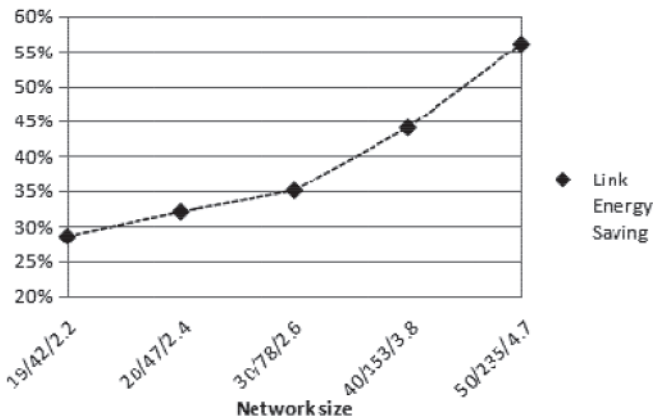

Fig.3 Link energy efficiency of LAR algorithm versus  $V_d$

link energy saving increases when is enlarged. A large improvement is noticeable when the value of  $V_d$  is up to 4.7. It may cases the alternate paths will become more because of the higher degree of nodes.

$$V_d = \frac{|V|}{|E|} \quad \dots (11)$$

where and denotes the number of nodes and links. According to the given traffic status of links obtained from SDN controller, the link utilization calculated by equation (6) will be used as link weight. To avoid the network congestion, it should set a threshold for the current total traffic through a link. Therefore, the maximum link utilization factor is forced to be small than 100% when routing algorithm select the best next hop. Then we performed a study on the impact of the maximum offered load of link to the number of links can be turned off by increasing factor. Fig.4 shows that the comparison of energy saving obtained using the LAR algorithm and the OE-LF heuristic algorithm in [8] under the network topology of nodal degree is 2.2. Two algorithms show larger improvements with increasing of . In particular, the LAR algorithm exhibits better performance in terms of saving energy on links very close to 40% for up to 0.8.

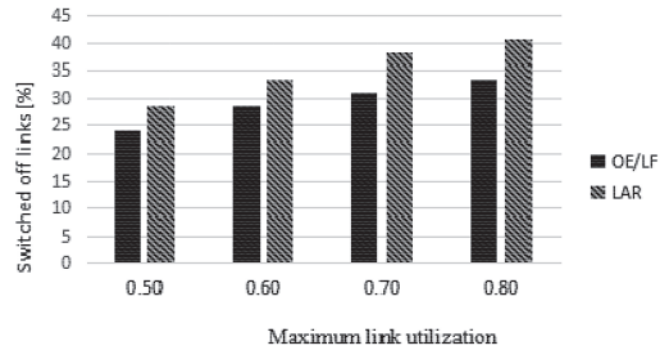

Fig.4 Percentage of links switched off with respect to

In the next work we conduct comparative experiments for network performance with the modified NSF Net topology after performing the LAR algorithm and the EAR algorithm in [6], considering  $\alpha = 0.5$ . The performance comparison between our algorithm and OE/LF algorithm cannot be obtained because the OE/LF algorithm turned off not only links but also nodes. For more intuitive effect, we choose the EAR algorithm to do the experiment. Through NS-2 simulator, we generate some flows correspond to traffic condition in low-peak period of real network during a simulation time and choose randomly the source and destination mode of each flow. Figs.5, 6 and 7 illustrate the comparison of delay, jitter and throughput. It shows that the network robustness of the LAR algorithm is greater than the EAR algorithm apparently from the figures, and the delay after running EAR scheme will up to 0.18 second. In addition, the span of jitter of EAR algorithm is much larger. Although the throughput is greater in Fig.7(b), the link utilization will exceed the threshold value

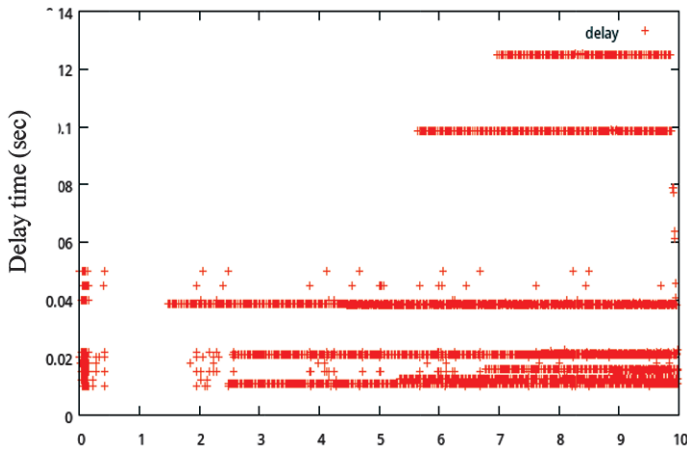
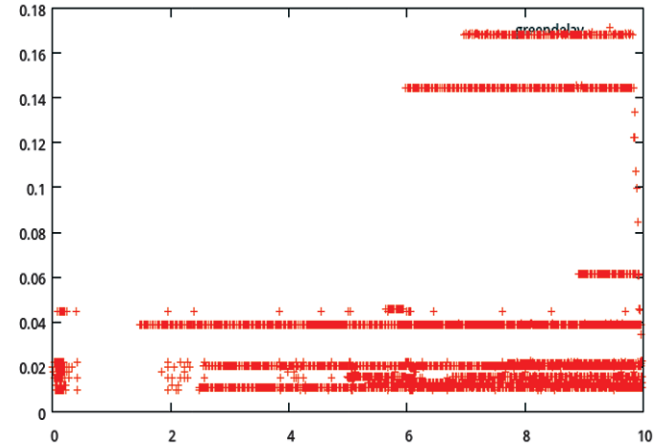

Fig.5(a) Delay of LAR scheme



(b) Delay of EAR scheme

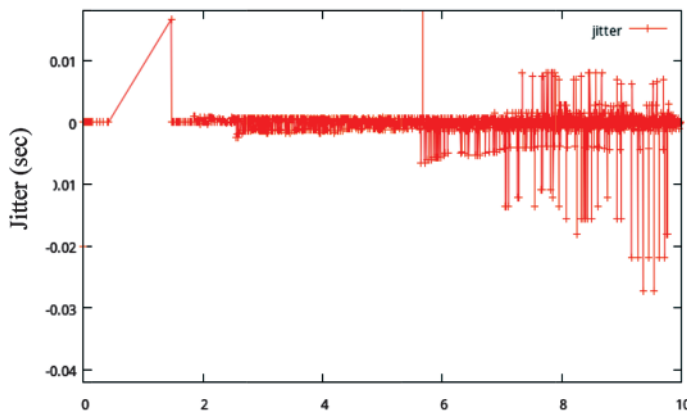
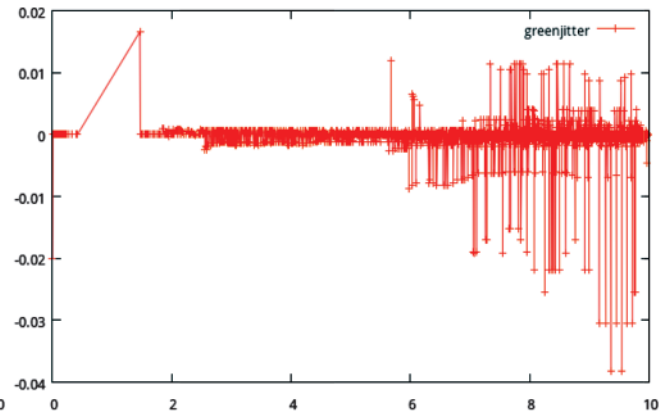

Fig.6(a) Jitter of the LAR scheme



(b) Jitter of the EAR scheme

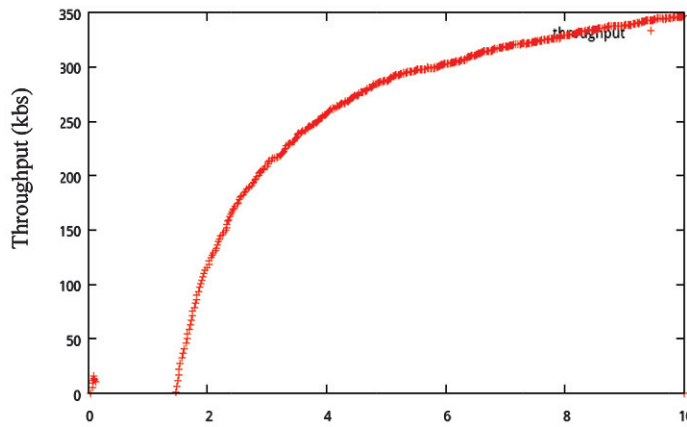
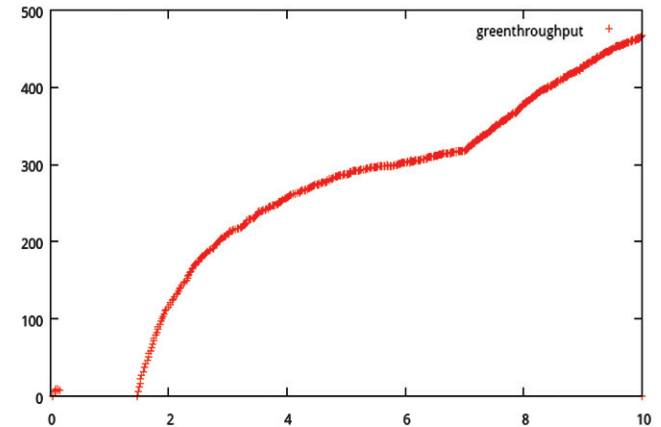

Fig.7(a) Throughput of the LAR scheme



(b) Throughput of the EAR scheme

later and it cannot get efficient load balancing. The case can be explained that EAR algorithm divides the flows to the less optional path.

### 5.0 Conclusions

In this paper, we proposed a new algorithm (LAR) based on the link bandwidth rate and achieve the considerable effect of energy saving in SDN network. To the best of our

knowledge, the energy consumption minimized network problem is a NP-complete problem. To solve it, we formulate it into a simpler one using the concept of Best Hop, and consider both the traffic centrality and network performance by the LAR algorithm. Comparing with other heuristic algorithms, the proposed algorithm has outstanding advantages in view of the complexity of algorithm and sustaining the performance of link.

Although a great energy-saving effect for a green routing scheme is the promising capability, a decline in the robust stability of network can never be ignored simultaneously. The simulations show that the proposed algorithm successfully reduces energy consumption to a certain degree when the link utilization parameter is adjusted.

#### Acknowledgments

This work is supported by Zhejiang Provincial key science and technology innovation team of China (No.2013TD20), National Science and Technology Support Program of China (No.2014BAH23F01-2), National 863 plan project of China (No:2015AA011901 No.2015AA015602), National High Technology Development program of China (No. 2015AA016102), Science and technology project of Zhejiang Province (No.2014C01051).

#### References

- [1] Guangming, C. (2014): "Research on the key issues of green network and component sleeping", *Nanjing University of Posts*.
- [2] Zuo, Qing Yun, (2013): "Research on Open Flow-based SDN technologies", *Journal of Software* 24.5, :1078-1097.
- [3] Christensen K, Nordman B, (2005): "Reducing the energy consumption of network device", *IEEE*,
- [4] Gunaratne C, Christensen K, Nordman B, et al, (2008): "Reducing the Energy Consumption of Ethernet with Adaptive Link Rate (ALR)", *IEEE Transactions on Computers*, 57(4): 448-461.
- [5] Nedeveschi, Sergiu, (2008): "Reducing Network Energy Consumption via Rate-Adaptation and Sleeping", *Proceedings of the 5th USENIX Symposium on Networked Systems Design and Implementation* USENIX Association, : 323-336.
- [6] Kim, Young Min (2012): "Ant colony based self-adaptive energy saving routing for energy efficient Internet", *Computer Networks* 56.10: 2343-2354.
- [7] Cianfrani, A. (2010): "An Energy Saving Routing Algorithm for a Green OSPF Protocol", *INFOCOM/IEEE Conference on Computer Communications Workshops*, IEEE, (2010): 1-5.
- [8] Chiaraviglio, L., M. Mellia, and F. Neri (2012): "Minimizing ISP Network Energy Cost: Formulation and Solutions", *IEEE/ACM Transactions on Networking*.
- [9] Chiaraviglio, Luca, M. Mellia, and F. Neri (2009): "Reducing Power Consumption in Backbone Networks", *IEEE International Conference on Communications*, 1-6.
- [10] Chiaraviglio, L., M. Mellia, and F. Neri (2009): "Energy-Aware Backbone Networks: A Case Study", *Communications Workshops, ICC Workshops 2009*, IEEE International Conference on IEEE, 1-5.
- [11] Wang, Rui (2014): "Energy-aware routing algorithms in Software-Defined Networks", *A World of Wireless, Mobile and Multimedia Networks (WoWMoM)*, 2014 IEEE 15<sup>th</sup> International Symposium on IEEE, 1-6.
- [12] Xu, Guan (2015): "Bandwidth-Aware Energy Efficient Routing with SDN in Data Center Networks", *High Performance Computing and Communications (HPCC), 2015 IEEE 7<sup>th</sup> International Symposium on Cyberspace Safety and Security (CSS), 2015 IEEE 12th International Conference on Embedded Software and Systems (ICCESS), 2015 IEEE 17th International Conference on IEEE*.
- [13] Wang Y, Chen H, Wu X. (2015): "An energy-efficient SDN based sleep scheduling algorithm for WSNs", *Journal of Network & Computer Applications*.
- [14] Bianzino, A.P. (2010): "Energy-Aware Routing: a Reality Check", *GLOBECOM Workshops (GC Wkshps)*, IEEE , 1422-1427.
- [15] Lin, Heng, M. Xu, and Y. Yang (2015): "Robust Energy-Aware Routing with Uncertain Traffic Demands", *IEEE International Conference on Computer Communications and Networks (ICCCN)*.
- [16] Yang Xiao qin (2012): "Routing algorithm based on link bandwidth utilization rate", *Journal of Computer Applications*, Sept.
- [17] Guan Li' an, Wang Binqiang, Zhu Xuanyong (2010): "Path Selection Algorithm Based on Residual Bandwidth and Link Utilization Rate of Next Hop", *Telecommunications Science*.
- [18] Wang Xinhong (2005): "TE Routing Algorithm to Minimize Maximum Link Utilization", *MINI-MICRO SYSTEMS*, March.

## INDIAN JOURNAL OF POWER & RIVER VALLEY DEVELOPMENT

*Special Issue on*

### OTPC – A SUCCESS STORY

*For copies, please contact:*

The Manager

**BOOKS & JOURNALS PVT. LTD.**

62 Lenin Sarani, Kolkata 700013 E-mail: [bnjournals@gmail.com](mailto:bnjournals@gmail.com)